

FLYING CIRCUS

I imagine, looking at the ratings in S&T that a lot of copies of 'Flying Circus' will be gathering dust in cupboards all over the country, which is a shame because the game can be improved.

Firstly, the map should be numbered, as the variation described here uses Simultaneous Movement. The top left-hand corner hex is 0101, top right-hand corner hex is 4501, and so on. By this numbering, target hex A is 0812 and hex B is 2014, and so on.

Sequence of Play

The new sequence of play is as follows:

1. Sighting phase players determine which aircraft are able to see an opponent (explained later on).
2. Aircraft sighted, that are on the same altitude and in range, may be fired at, and may return fire. Any damage is registered in the speed counters, and ammunition counters are reduced.
3. Players plot movement, in accordance with the plotting rules which are explained later.
4. The aircraft are moved.

Field of Fire Modification

The field of fire, of rear swivel-mounted guns and rear ring-mounted guns, remains the same as before, but for forward firing guns it is slightly modified: at 6-8 hexes range, the hexes on either side of the field of fire can be fired into, this simulates the pilot's ability to 'yaw' the aircraft through

about 15 degrees to either side.

The table below is used to introduce some difference between target aspects of aircraft in different situations i.e. an aircraft flying across the field of fire is harder to hit than one which is being chased.

Target	Range	
	1-4	5-8
Receding	1	2
Moving across field of fire	2	2
Being attacked from above	-1	0
Diving	0	1

The numbers are to be added to the die-roll, e.g. an aircraft which is attacked from above at 3 hexes range, if a 3 is thrown it becomes a 2. A one stays a one, six a six.

When an aircraft is hit there is a chance that the pilot could be killed outright, and in a two-seater either or both occupants could be killed.

	Damage					
	1	2	3	4	5	6
Dice-throw to kill	1	1	1,2	1,2,1	2,1-3	1-3

Whenever an aircraft is hit shake on the above chart, shake twice for a two-seater.

Plotting Movement

In a move an aircraft may dive, climb, increase or reduce speed.

Increase speed by X	'IS X'
Decrease speed by X	'RS X'
Climb	'CL'
Dive	'DV'

Anywhere on the map one or two direction roses may be drawn to help plotting.

A
F B
E C
D

An example of plotting: an aircraft moving at a speed of 10 and also climbing, must reduce speed by at least 1mp.

The plot would be RS 1 CL 4A 3F, from which it can be seen that the aircraft also turned.

If two aircraft at the same height wish to complete their movement in the same hex, both players throw a dice. The player throwing the higher number may then move his aircraft into the hex. If both dice are the same then the aircraft have collided and are removed from play. If the aircraft which had to turn away, was a B or D turn mode aircraft, then it must begin its turn in the previous hex.

Typical Target Areas

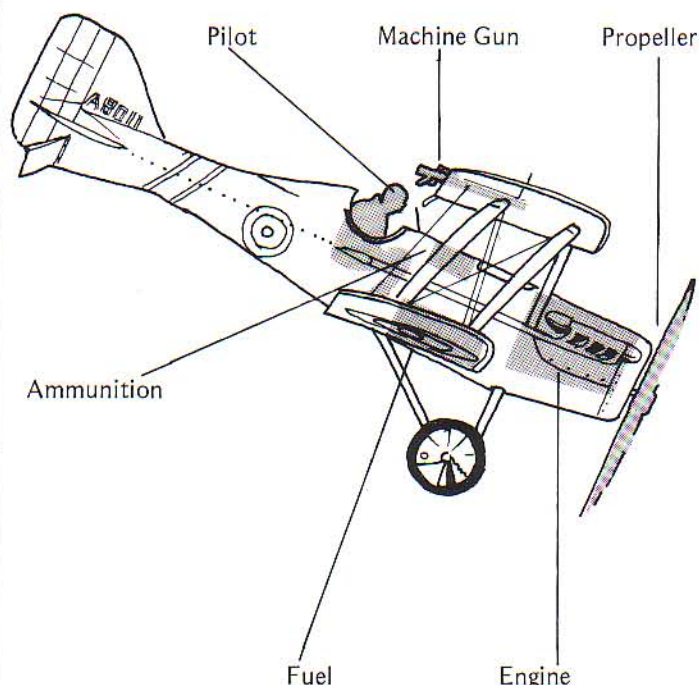

Special Offers from SPUK

All prices include postage and packing

Strategy & Tactics (without game) 50p each

- No.38 (Pacific Naval Tac; Gettysburg)
- No.42 (Sino-Soviet Conflict; Waterloo)
- No.43 (Civil War, Soldier King)
- No.44 (Tank!; Sea War in the Age of Sail)
- No.46 (Combined Arms Doctrine; Inf. Tactics)
- No.48 (Sixth Fleet; Global War)
- No.49 (Fred. the Great; Civil War Battles)
- No.50 (Battle for Germany; Dreadnought)
- No.51 (WWI; Fast Carriers)
- No.52 (Oil War; Island War)

Moves 35p each

- No.14 (Kampfpanzer & Desert War)
- No.16 (World War II Profile and Variants)

Blank Counter Sheets (Style 1)

- ½ doz. White Type "A".....£1.25
- ½ doz. Grey Type "A".....£1.25
- ½ doz. Tan Type "A".....£1.25
- ½ doz. Olive Type "A".....£1.25
- ½ doz. White Type "B".....£1.25
- ½ doz. Grey Type "B".....£1.25
- ½ doz. Tan Type "B".....£1.25
- ½ doz. Olive Type "B".....£1.25

Standard Games

- Sinai (Boxed).....£3.50
- Sinai (Unboxed).....£2.50
- Seelowe (Boxed).....£3.50
- Seelowe (Unboxed).....£2.50
- Normandy (Boxed).....£3.50
- Normandy (Unboxed).....£2.50

This special offer is valid on orders received up to March 18th, 1977. We reserve the right to cancel or alter this offer at any time without prior notice. No discounts may be taken on the prices quoted above.